

THE SEALED LIQUIDS

Specific Gravity

- Is a dimensionless number
- It is the ratio of a fluid's **density** to that of Water
- Water has a specific gravity of 1
- A fluid with a specific gravity of 0.5 weighs 1/2 as much as the same volume of Water

Specific Heat

- The Amount of **Heat**, in number of **Calories**, that is required to raise the Temperature of one gram of a **Liquid** one degree **Celsius**
- **Specific Heat** is also expressed as the number of **British Thermal Units (BTU's)** necessary to raise the Temperature of one pound of a **Liquid** one degree **Fahrenheit**

Specific Heat

- The **Specific Heat** of **WATER** is one **Calorie** per degree **Celsius**
- One **Calorie** of **heat** must be supplied to a gram of **WATER** to raise the **Temperature** one degree **Celsius**
- The **Specific Heat** of **WATER** is one **BTU** per degree **Fahrenheit**
- One **BTU** of **Heat** must be supplied to a Pound of **WATER** to raise the **Temperature** one degree **Fahrenheit**

Vapor Pressure

- Is also known as the Boiling Point
- Is the Pressure Below which a liquid at a given temperature will become a gas
- Is the Pressure Above which a gas will become a liquid

Vapor Pressure

What is the Vapor
Pressure of **WATER** at
Sea Level ?

What is the **Coldest**
Temperature at which you can
Boil **WATER**?

Viscosity

- **VISCOSITY:** Property of a **FLUID** that tends to prevent it from Flowing when subjected to an Applied Force.
- **High-Viscosity Fluids** Resist Flow;
Low-Viscosity Fluids Flow Easily.
- The Tenacity with which a Moving Layer of Fluid drags adjacent Layers of Fluid along with it Determines its Viscosity!

Viscosity

**VISCOSITY EQUALS
LUBRICITY WHEN
DISCUSSING MECHANICAL
SEALS**

LIQUIDS CHANGING STATE

- **FREEZE**
- **SLUSH**
- **VAPORIZING / COLLAPSING**
- **POLYMERIZING**
- **SHEAR SENSITIVE**
- **THIXOTROPIC FLUIDS**
- **EXOTHERMIC REACTIONS**
- **COKING / REACTING W
ATMOSPHERE**

HOMOGENEOUS LIQUIDS

- **1. HAVING UNIFORM COMPOSITION:**
A Liquid having a Uniform
Composition.

LIQUID MIXTURES

- 1. **BLEND OF INGREDIENTS:** A Liquid Substance containing several ingredients combined or blended together.
- 2. **CHEMISTRY:** Liquid Substance formed without Chemical Reaction: a substance consisting of two or more substances that have been combined without chemical bonding taking place

LIQUID COMPOUNDS

- **1. CHEMISTRY: A Liquid Substance Formed by the Combination of Two or More different Liquids + Substances**

LIQUIDS WITH DISSOLVED SOLIDS

- **1. CHEMISTRY: A Liquid Substance with One or More Solids Dissolved in it.**

LIQUIDS WITH UN-DISSOLVED SOLIDS

- **1. CHEMISTRY: A Liquid Substance with One or More UN-Dissolved Solids or Particles in it.**

LIQUIDS WITH DISSOLVED GASSES

- **1. CHEMISTRY: A Liquid Substance with One or More Dissolved Gasses in it.**
- **A Liquids Ability to Absorb a Gas is Inversely Related to Temperature**

SOLIDS / PARTICLES IN LIQUIDS

GENERALLY

Specific Gravity of Particles

Specific Gravity of Liquid

- A Number >1 = Particles will Displace Liquid Toward the Rotating Shaft
- Stated Differently Particle is Centrifuged Away from the Shaft

SOLIDS / PARTICLES IN LIQUIDS

GENERALLY

Specific Gravity of Particles

Specific Gravity of Liquid

- **A Number <1 = Liquid will Displace Particles Toward the Rotating Shaft**
- **Stated Differently Liquid is Centrifuged Away from the Shaft**

SOLIDS, PARTICLES, & FLAKES IN LIQUIDS

- **The Behavior of a Solid, Particle, or Flake Inside a Pump Stuffing Box is Highly Dependent on its Shape.**
- **The Solid's Shape and Fluid Turbulence Pattern Inside the Stuffing Box will determine its behavior**

Seal Cavity Flow Components

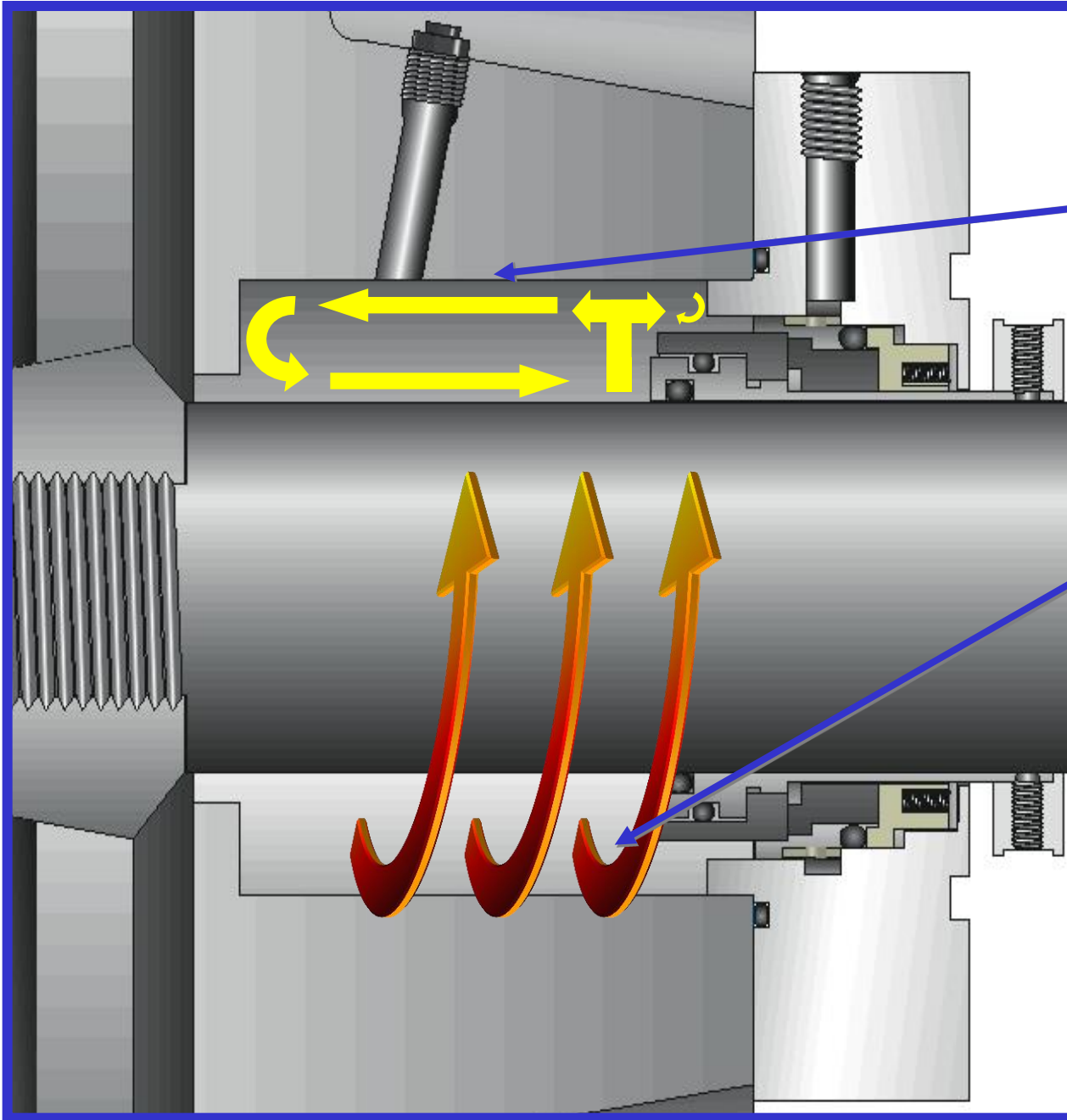

- **Axial flow**
Driven by rotating radial surfaces like the back of the seal

- **Rotational (Angular Flow)**
Developed by shaft rotation.

Rotational Flow

- **Abrasives**
Driven out to the bore
- **Air**
Driven in to surround the shaft

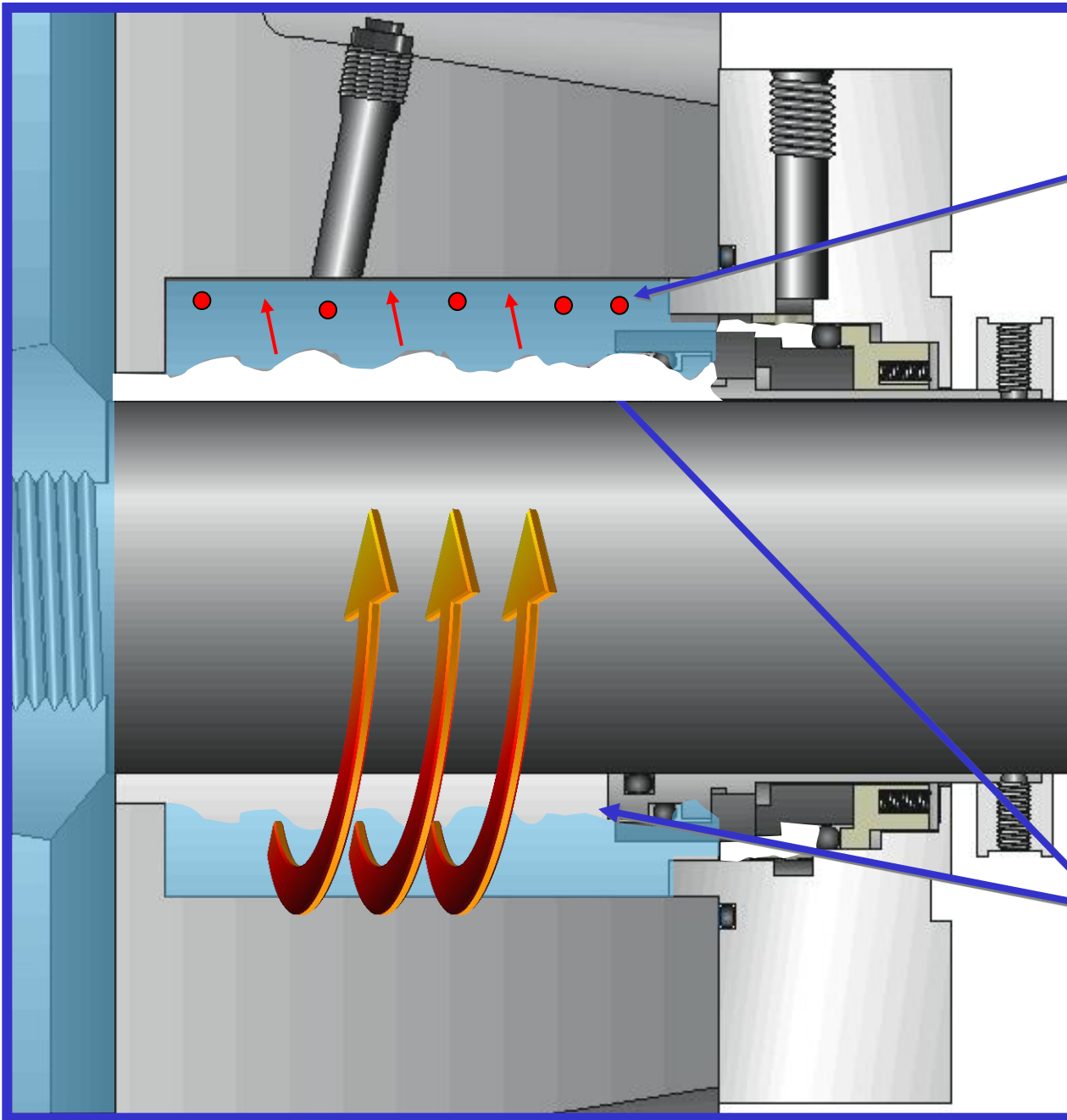

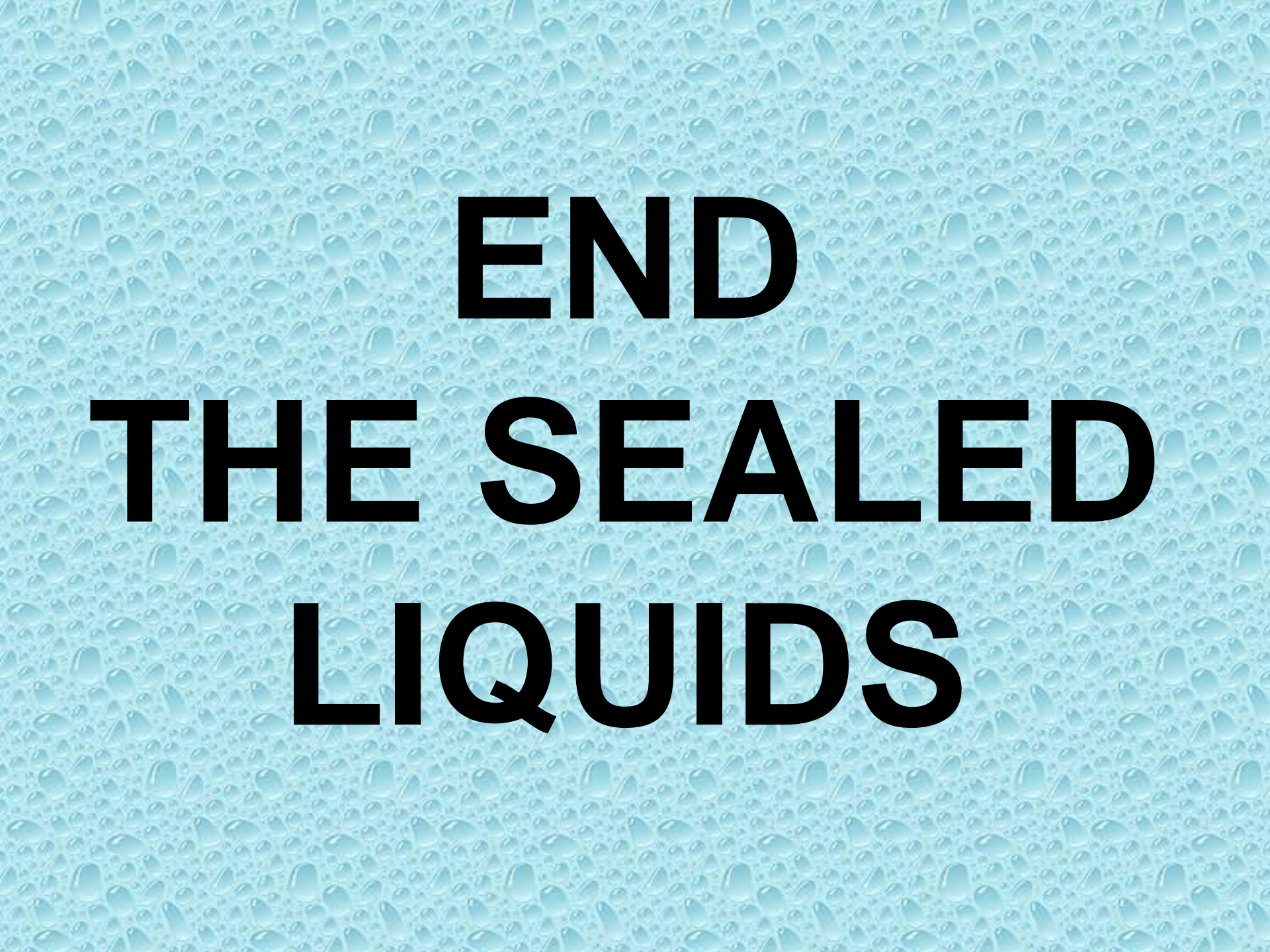

**END
THE SEALED
LIQUIDS**